

Keep this  
manual onboard !

# **Installation and user instructions**

*To be used in addition to the main thruster manual*



## **IMPORTANT NOTICE:**

*This manual is to be used in addition to the regular installation manual for the Sidepower thruster.*

*This manual is intended for professionals only that can read and understand a wiring diagram, and does not contain all detailed work instructions for what must be done to ensure correct and safe installation*



**SLEIPNER MOTOR AS**

P.O. Box 519  
N-1612 Fredrikstad  
Norway  
Tel: +47 69 30 00 60  
Fax: +47 69 30 00 70

[www.side-power.com](http://www.side-power.com)  
[sidepower@sleipner.no](mailto:sidepower@sleipner.no)



Made in Norway

## Installation of the Sidepower automatic main switch

**Note!** *To achieve maximum effect, reliability and durability from your Sidepower thruster, a correct installation as per the instructions are very important. Please follow the instructions carefully, and make sure that all checkpoints are carefully controlled.*

### INTRODUCTION - DESCRIPTION OF FUNCTION:

The Sidepower automatic main switch product was developed to further enhance the safety and ease of use of a Sidepower thruster system. The automatic main switch ensures that there is no power at the thruster unless you actually intend to use the thruster. It is controlled by the Sidepower control panel / Sidepower control device, and also benefits from the Auto-Off features in these products so that if you forget to shut it off, it will automatically shut off after a preset time.

This also means that in case of a failure, the main switch is fast and easy to shut off without leaving the steering position simply by pushing the OFF on the control panel, which should be the logic thing to do even in a panic situation.

To comply with regulations the automatic mainswitch also has a mechanical shut-off feature on the main switch itself. This is a backup in case there is a failure in the switch.

The built-in fuse holder is made for ANL type fuses with special provisions to reduce voltage drop and heating. By the fuse being part of the unit, you avoid fitting two separate items to comply with having both a fuse and a main switch on the thruster main circuit.

### INSTALLATION PLANNING AND PRECAUTIONS:

- The automatic main switch should be fitted as close to the battery(ies) as possible.
- Do not fit the automatic main switch with other than the appropriate original Sidepower control panels or other Sidepower control devices specifically designed for this with a separate fifth control lead for the automatic main switch.
- It is designed to fit on a shelf or a wall and must be fitted so that it keeps dry at all times.
- The automatic main switch can NOT be fitted in spaces requiring Ignition protected equipment.
- Make sure that the fuse you order for the main switch is the correct one for the thruster it is being fitted with.
- The control cables must be routed differently from an installation without this automatic main switch so that the 4-lead control cable from the thruster follows the main battery cables to the main switch, and then you use 5-lead control cables from the main switch to the control panels. This can accommodate basically an unlimited number of Sidepower controls, including a radio remote by branching off with Y-connectors.
- If any of the Sidepower control panels are situated outside or in a place where they can be accessed when the boat is not in use, the control power for the automatic main switch should be taken over another main switch that will be off when the boat is not in use.
- Failure to install the automatic main switch in accordance with this manual will render all warranty void and can cause malfunction or even serious damages.

## Installation of the Sidepower automatic main switch

### Fitting the fuse and battery cable(s).

- Remove the nuts and all the washers (B, D and F).
- Fit the fuse (C) on top of the pre-fitted conductors (A) and washer (B).
- Fit the washers (D) and battery cable(s) (E) as shown below.
- Fit the washers and nut (F).
- Tighten the nut carefully with 20Nm(14.5 lb/ft) torque, as the brass bolt is weaker than a steel bolt.

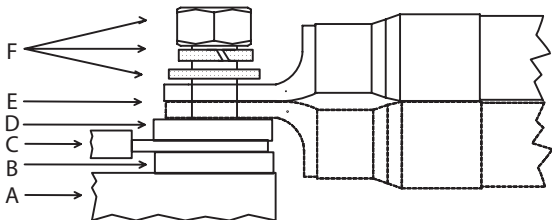
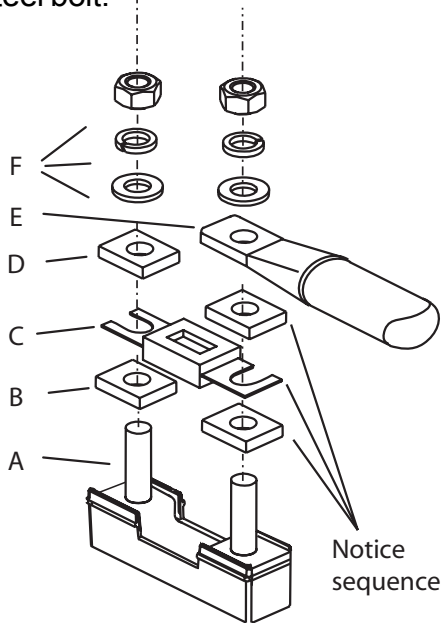

### Fitting the thruster cable(s)

- Remove the nuts and washers (C, D and E).
- Fit the cable or cables (B) as shown directly onto the pre-fitted conductor (A).
- Fit the washers in sequence as shown with the flat washer (C) on top of the cable and the springwasher (D) under the nut (E).

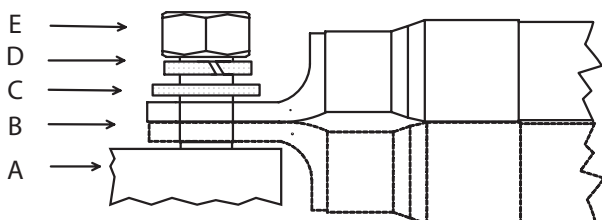

### Description of the automatic main switch

Manual over ride button.  
Push to shut OFF  
Pull to activate ON

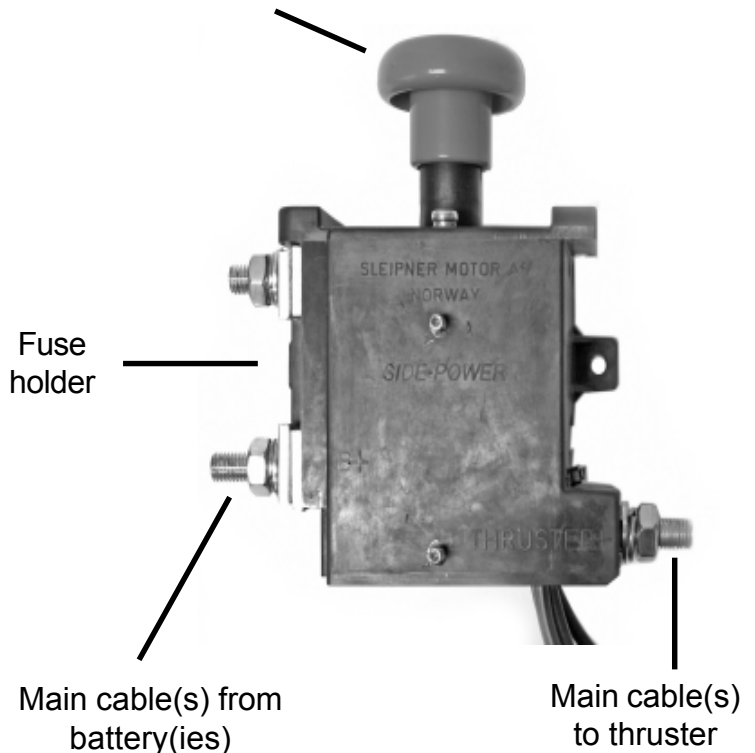

### Manual override button.

- Pull OUT for ON
- Push IN for OFF
- Leave the switch in ON position when on board
- Make sure the switch is in OFF position when leaving the boat for a long period or when you are installing or servicing the thruster system

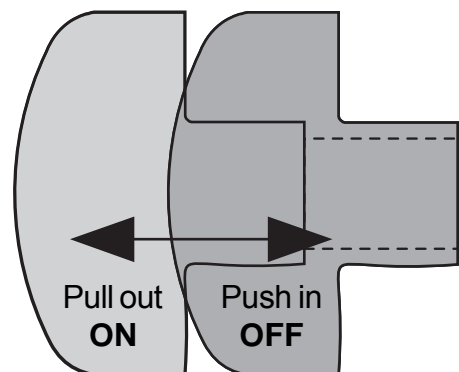

### **Wiring of the automatic main switch**

- Fit the automatic mainswitch as close to the battery(ies) as possible making sure that it is in a position so that it will stay dry at all times.
- Use a 4-lead control cable between the thruster and the automatic mainswitch (only 3 leads is in actual use, red is not wired into the automatic mainswitch).
- Use 5-lead control cables between automatic mainswitch and control panels, using 5-lead Y-connectors to branch off to all controls fitted.
- Use the table in the thrusters manual for deciding the main cable sizes, the lengths are the total of positive and negative, all the way from the battery.

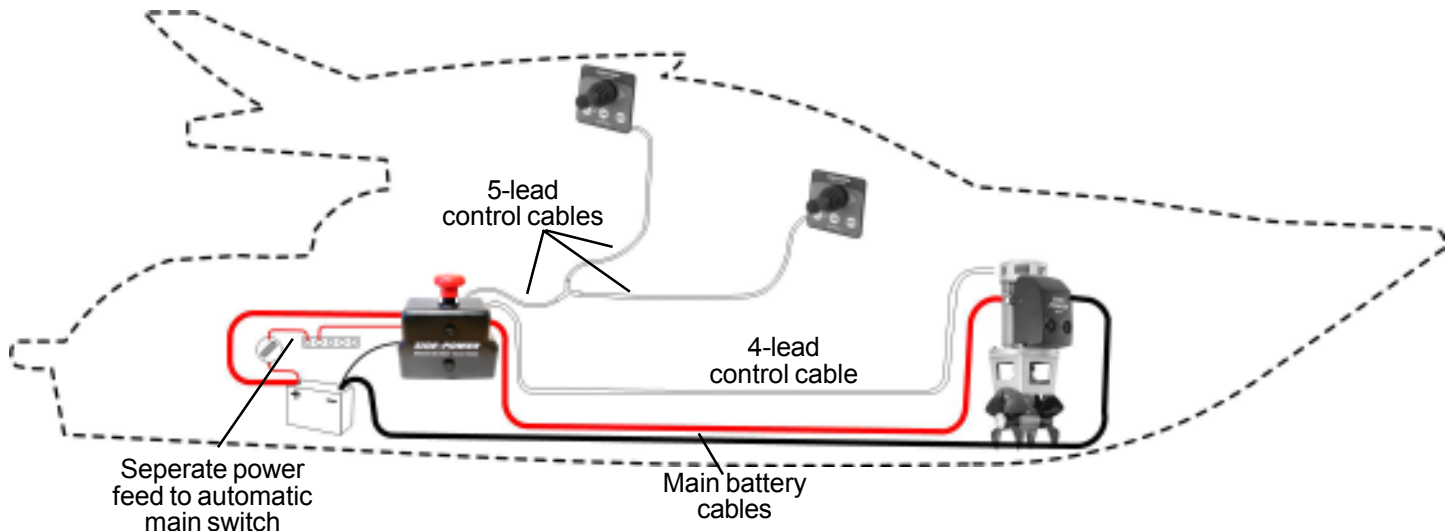

DESCRIPTION OF WIRING DIAGRAMS (as shown on opposite page):

- A Main switch with fuse, 12 or 24V version.  
Order correct fuse size depending on thruster it is being fitted with
- B The thruster panel(s) ON/OFF system with timer auto-off and safe dual ON button activation controls the Automatic main power switch
- C The thermal switch built into the thruster motor which supply all the negative/ground to the panel so that in an over-heat situation also the automatic main power switch will be shut off.
- D To prevent the possibility of the thruster being activated by an outside mounted thruster panel when nobody is onboard, the positive control power must be supplied over one of the boats main battery switches or alternatively the ignition switch if you wish to prevent usage of the thruster unless the main engine is running. This power feed must be fused to protect the wire.  
- If there are no outdoor control panels or the main power to the automatic mainswitch is supplied through one of the boats manual mainswitches, this wire can be connected to the main positive input terminal on the automatic mainswitch in which case it does not need to be fused. If so, the automatic mainswitch can always be activated by any panel on board.
- E The mainswitch must have a negative power feed for its solenoid.

When you fit two thrusters you need to fit an automatic main switch for each thruster, except for the models SP30S2i, SP40S2i, SP55Si12, SP55Si24 and SP75Ti24 for which one automatic mainswitch can support two thruster because of the low current consumption. This installation also requires that only one battery bank is used to power both thrusters.

It is important that the battery banks powering the thrusters have a common negative so that the voltage potential is equal. If this is not so in the boat you are installing the thrusters in, both thrusters have to be powered from one battery bank (of sufficient size).

Single thruster wiring

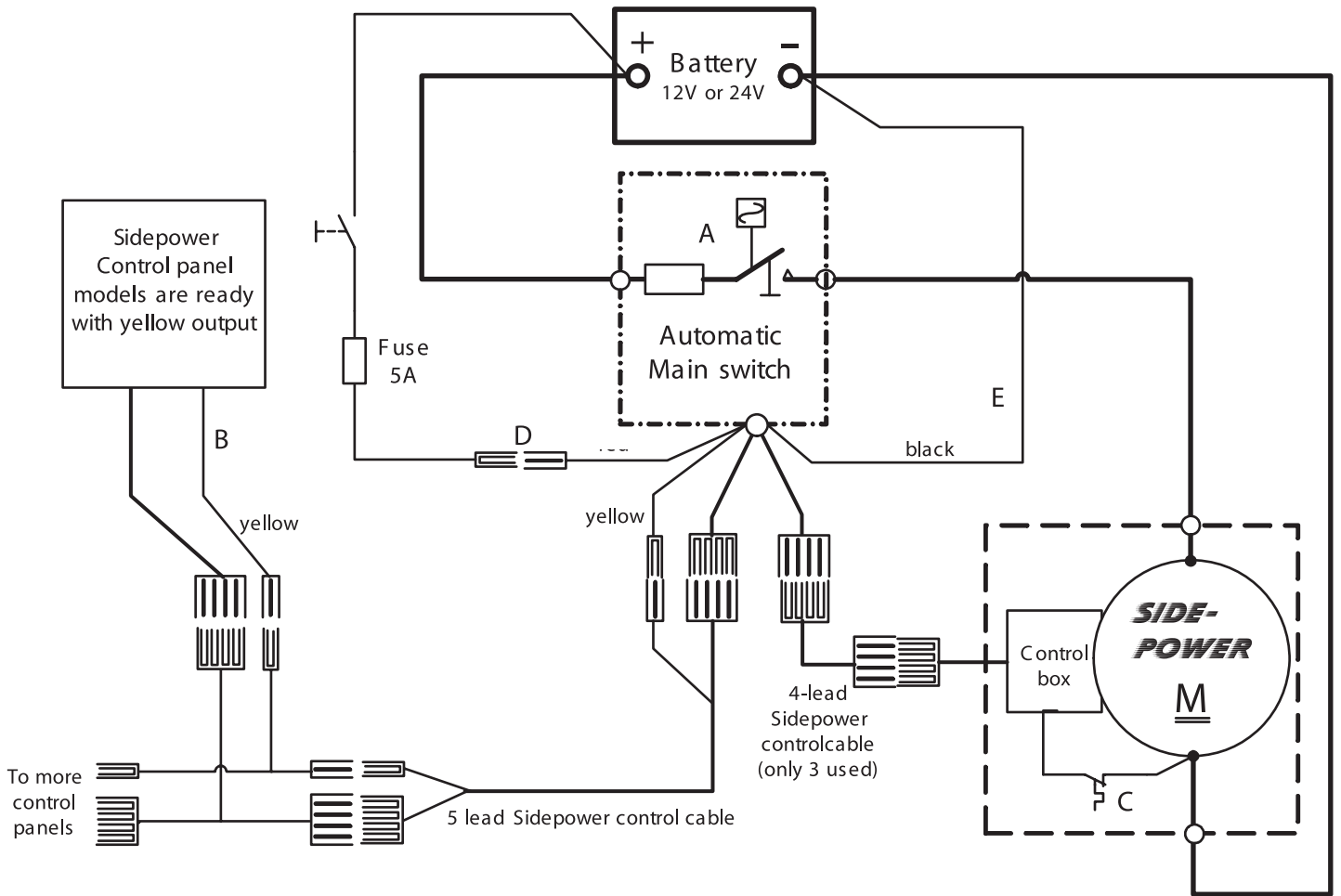

Dual thrusters wiring

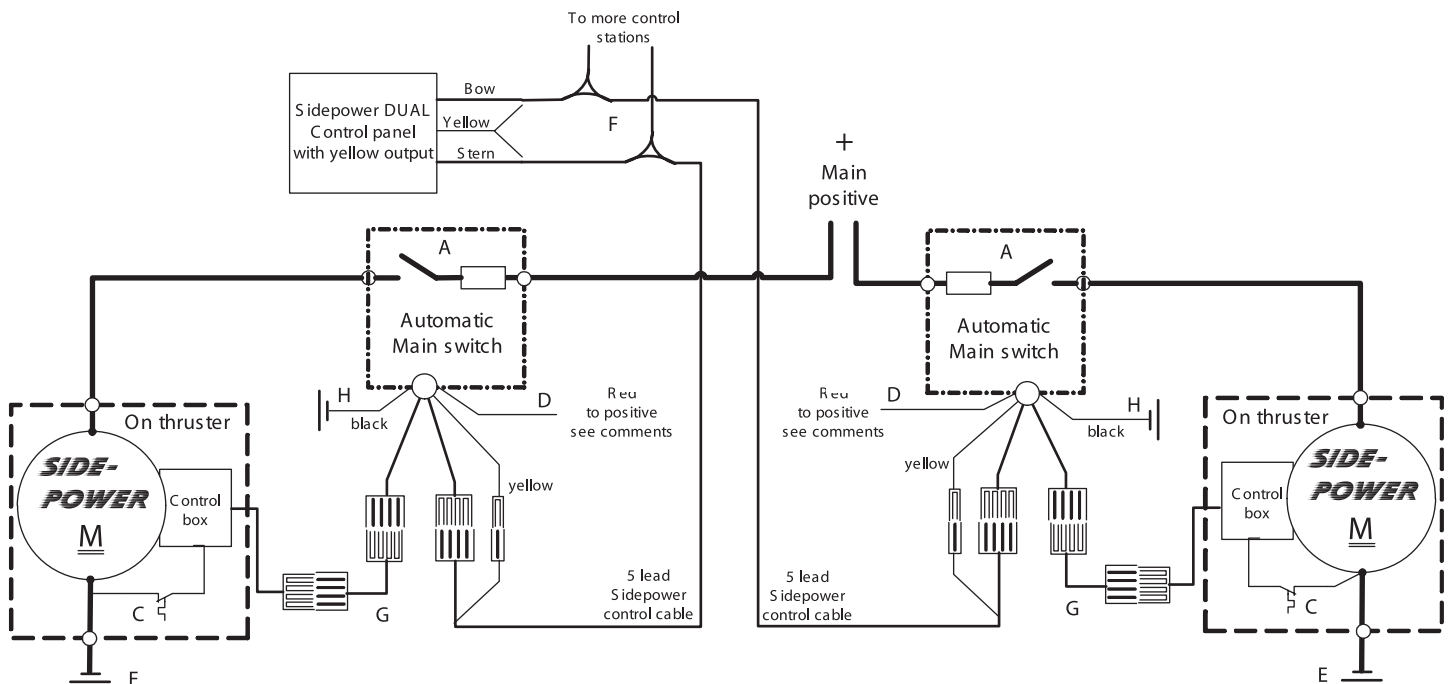

## Instructions and wiring diagram for use with series / parallel switch box installation

### Description:

**IMPORTANT ! Only versions 897512A and 897524A is compatible with series / parallel box installations**

- Fit the automatic mainswitch as close to the battery as possible.
  - Use a 4-lead control cable between the thruster and the automatic mainswitch.
  - Use 5-lead control cables between automatic mainswitch and control panels, using 5-lead Y-connectors to branch off to all controls fitted.
  - Use the table in the thrusters manual for deciding the main cable sizes, the lengths are the total of positive and negative, all the way from the battery.
- A Main switch with fuse, 12 or 24V version. Use the version of the boats original voltage, so that for SP155, 200 or 240 being fitted in 12V boats, use 12V mainswitch. For SP285TC fitted in 24V boat use 24V mainswitch. Select fuse size depending on thruster.
- B The thruster panel(s) ON/OFF system with timer auto-off and safe dual ON button activation controls the Automatic main power switch.
- C The thermal switch built into the thruster motor which supply all the negative/ground to the panel so that in an overheat situation also the automatic main power switch will be shut off.
- D When installing the automatic mainswitch in a series / parallel type installation the power to the internal functions of the automatic mainswitch must be taken from the systems batt. 1 so that it is in the boats native/original voltage level.
- E The mainswitch must have a negative power feed for its solenoid and this must also be taken from the batt. 1 negative so that it is always at the boats general negative/ground voltage.
- F Install and wire series / parallel box as described in its installation instructions, replacing the fuse and mainswitch between batt. 2 and the thruster with this automatic mainswitch.
- Dotted lines here only show schematically the other main cables used when fitting a series/parallel system, refer to detailed instructions in the actual installation manual of this item.
- G A fuse and manual main switch should be fitted between battery bank 1 and the series parallel switch box so that it can be shut down in case of a fault. However, this should be left on at all times to ensure charge of "Batt. 2" and only be disconnected when installing / servicing or in case of a failure. This
- PS! Do NOT use an automatic mainswitch between Batt 1 and Batt 2 as this will prevent charging of batt.2. The mainswitch between the batteries are only for emergencies and should always be left in the ON position except in emergencies.

### Wiring with series / parallel switch box installation

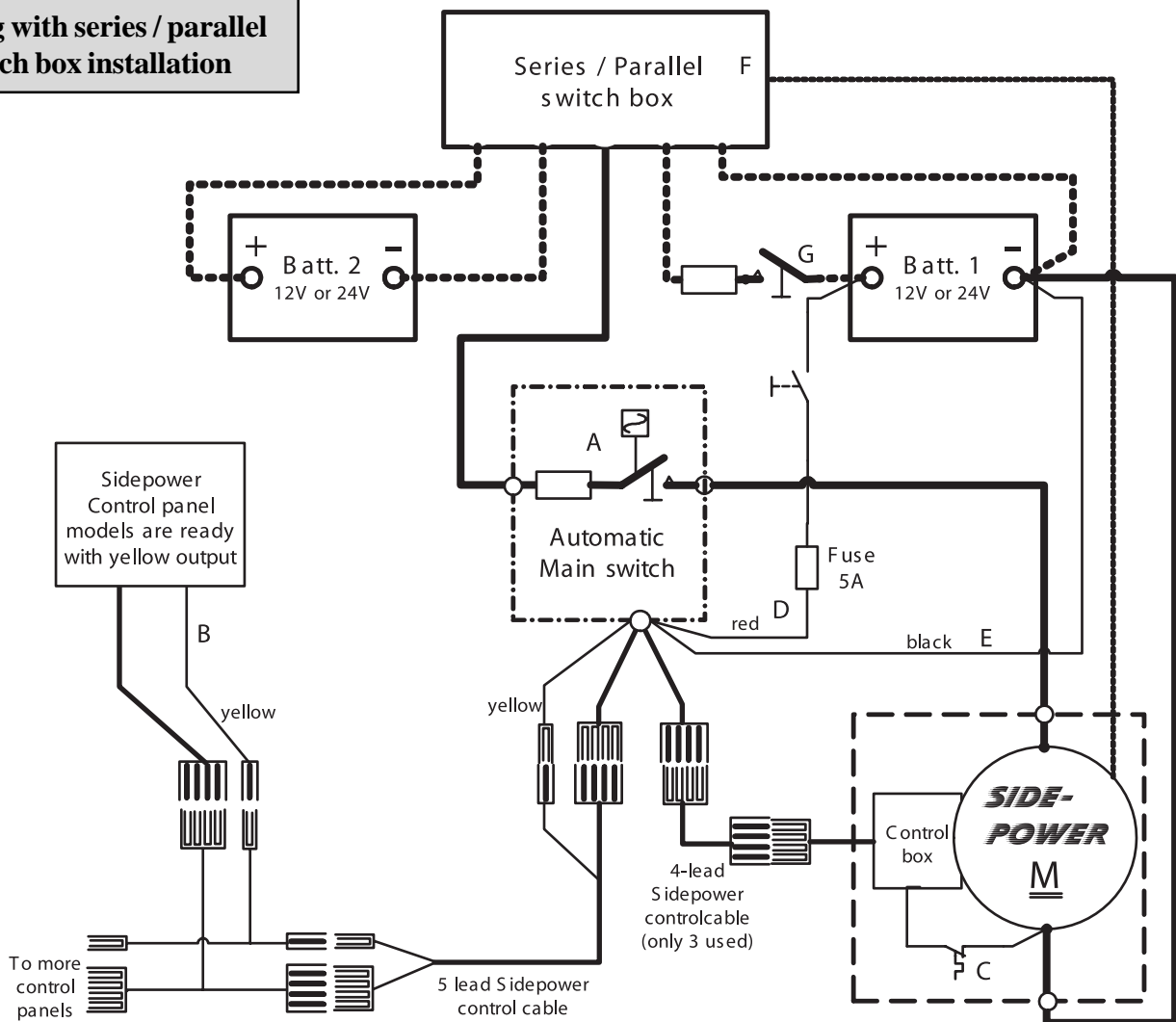

### Service / maintenance

- The automatic mainswitch does not require specific service or maintenance other than normal service and control that should be performed on all electric equipment regularly which includes:
  - Keeping the equipment clean and dry.
  - Making sure all cable and other connections are tight and without signs of excessive heat or corrosion.

### Trouble shooting

*The control panel will not activate:*

- Make sure that the automatic mainswitch is getting positive feed over its red thin lead. If this goes over another main switch in the boat, make sure that this is ON.
- Check that the internal overheat switch (bi-metal switch on the circuit board) in the automatic main switch has not opened. It is automatically re-setting so that if it is open while the mainswitch is cold, contact your nearest Sidepower service for assistance. You should also investigate the reason why it opened in the first place.
- Check 5A fuse installed on the red positive cable to the automatic main switch.
- Check that the overheat switch in the electromotor has not blown due to excessive heat.
- Check all control cable connections against the wiring diagrams in this manual and the thrusters manual.

*The control panel activates, but the thruster will not run*

- Make sure that the manual over-ride knob is in "ON" position (pulled out).
- Check that the main power fuse in the automatic mainswitch is OK - if it is blown, please ensure that it is the right size. If it is the correct size but the fuse continue to blow, the reason for this must be identified.
- Check if the main switch activates when the control panel is activated. If not, please check the wiring, especially that you have a constant separate negative feed (thin black lead) and that the control panel is feeding a positive into the yellow lead.
- Check that there is power at the thruster. If it is not while the previous points are checked OK, the main cable run must be checked.
- If there is power at the thruster, measure the voltage at the main battery cable connection points into the thruster while you are trying to run the thruster. If this is below 8,5V (12V system) or 16V (24V system) control the batteries and main cable runs to find the reason for the excessive voltage drop.
- Go through the trouble shooting in the thrusters manual.

If you are unable to identify and resolve the problem by these actions, please contact the nearest Sidepower service point for assistance and please have the notes from your trouble shooting handy to inform the service person of what you have already checked and found.



## DECLARATION OF CONFORMITY

**We, Sleipner Motor AS  
P.O. Box 519  
N-1612 Fredrikstad, Norway**

**declare that this product complies with the essential health and safety requirements according to Directive 89 / 336 / EEC of 23 May 1989 amended by 92 / 31 / EEC and 93 / 68 / EEC.**

## Service Centres

### Argentina

Trimer SA  
Buenos Aires  
Tel: +54 11 4580 0444  
Fax: +54 11 4580 0440  
www.trimer.com.ar  
trimer@trimer.com.ar

### Australia

AMI Sales  
Freemantle, WA  
Tel: +61 8 9331 0000  
Fax: +61 8 9314 2929  
ami@amisales.com.au

### Austria

G. Ascherl GmbH  
Hard, Bregenz  
Tel: +43 5574 899000  
Fax: +43 5574 89900-10  
www.ascherl.at  
office@ascherl.at

### Benelux

ASA Boot Electro  
Watergang  
Tel: +31 20 436 9100  
Fax: +31 20 436 9109  
asaboot@worldonline.nl  
info@asabootelectro.nl

### Canada

Imtra Corporation  
New Bedford, MA  
Tel: +1 508 995 7000  
Fax: +1 508 998 5359  
www.imtra.com  
side-power@imtra.com

### Croatia

AC Yacht & nautical support  
Icici  
Tel: +385 51 704 500  
Fax: +385 51 704 600  
acy@net.hr

### Denmark

Gertsen & Olufsen AS  
Hørsholm  
Tel: +45 4576 3600  
Fax: +45 4576 1772  
www.gertsen-olufsen.dk  
info@gertsen-olufsen.dk

### Finland

Nautikulma OY  
Turku  
Tel: +358 2 2503 444  
Fax: +358 2 2518 470  
www.nautikulma.fi  
nautikulma@kolumbus.fi

### France

Kent Marine Equipment  
Nantes  
Tel: +33 240 921 584  
Fax: +33 240 921 316  
www.kent-marine.com  
contact@kent-marine.com

### Germany

Jabsco GmbH  
Norderstedt  
Tel: +49 40 535 373-0  
Fax: +49 40 535 373-11

### Greece

Amaltheia Marine  
Athens  
Tel: +30 210 2588 985  
Fax: +30 210 2588 986  
www.amaltheiamarine.com  
amalmar@otenet.gr

### Iceland

Maras EHF  
Reykjavik  
Tel: +354 555 6444  
Fax: +354 565 7230  
www.merkur.is  
velar@merkur.is

### Ireland

Sleipner Motor Ltd.  
South Brent  
Tel: +44 1364 649 400  
Fax: +44 1364 649 399  
andy@sleipner.co.uk

### Israel

Atlantis Marine Ltd.  
Tel Aviv  
Tel: +972 3 522 7978  
Fax: +972 3 523 5150  
www.atlantis-marine.com  
atlantis@inter.net.il

### Italy

Saim S.P.A.  
Assago-Milan  
Tel: +39 02 488 531  
Fax: +39 02 488 254 5  
www.saim-group.com

### Japan

Turtle Marine Inc.  
Nagasaki  
Tel: +81 95 840 7977  
Fax: +81 95 840 7978  
www.turtle-marine.com  
info@turtle-marine.com

### Malta

S & D Yachts Ltd.  
Cali  
Tel: +356 21 339 908  
Fax: +356 21 332 259  
www.sdyachts.com  
info@sdyachts.com

### New Zealand

Lusty & Blundel Ltd.  
Auckland  
Tel: +64 9 415 8303  
Fax: +64 9 415 8304  
www.lusty-blundell.co.nz  
sales@lusty-blundell.co.nz

### Norway

Sleipner Motor AS  
Fredrikstad  
Tel: +47 69 30 00 60  
Fax: +47 69 30 00 70  
www.side-power.com  
sidepower@sleipner.no

### Poland

Taurus Sea Power SP. Z.O.O  
Gdansk  
Tel: +48 58 344 30 50  
Fax: +48 58 341 67 62

### Portugal

Krautli Portugal Lda.  
Lisboa  
Tel: +351 21 953 56 00  
Fax: +351 21 953 56 01  
www.krautli.com  
contact@krautli.pt

### Russia

Standarte  
Starbeyevo  
Tel: +7 495 575 67 23  
Fax: +7 495 575 39 77  
www.standarte.ru  
info@standarte.ru

### Spain

Imnasa Marine Products  
Girona  
Tel: +34 972 820210  
Fax: +34 972 325116  
www.imnasa.com  
imnasa@imnasa.com

### Sweden

Sleipner AB  
Strömstad  
Tel: +46 526 629 50  
Fax: +46 526 152 95  
www.sleipnerab.se

### Switzerland

Marine Parts Technics AG  
Volketswil  
Tel: +41 44 997 40 90  
Fax: +41 44 997 40 94  
www.marineparts.ch  
info@marineparts.ch

### Singapore/Malaysia/ Indonesia

Alquest Marketing  
Singapore  
Tel: +65 6749 9359  
Fax: +65 6749 9360  
www.alquest.com.sg  
alquest@singnet.com.sg

### Singapore/Malaysia/ Indonesia

OK-Maritime Pte Ltd  
Singapore  
Tel: +65 9669 8051  
Fax: +65 6769 0507  
www.ok-maritime.com  
sales@ok-maritime.com

### Taiwan

Mercury Marine Supply  
Kaohsiung  
Tel: +886 7 8133 233  
Fax: +886 7 8133 236

### Turkey

Denpar Ltd.  
Istanbul  
Tel: +90 212 285 0334  
Fax: +90 212 285 0311  
bilgebay@superonline.com

### UK

Sleipner Motor Ltd.  
South Brent  
Tel: +44 1364 649 400  
Fax: +44 1364 649 399  
andy@sleipner.co.uk

### United Arab Emirates

Teignbridge Propulsion  
Dubai  
Tel: +971 4 324 0084  
Fax: +971 4 324 0153  
teignpro@emirates.net.ae

### USA

Imtra Corporation  
New Bedford, MA  
Tel: +1 508 995 7000  
Fax: +1 508 998 5359  
www.imtra.com  
side-power@imtra.com

### All other:

Sleipner Motor AS

